

## INSTALLATION

The ATxRail transmitter is intended for DIN rail mounting. Its drawing is presented in figure 4.

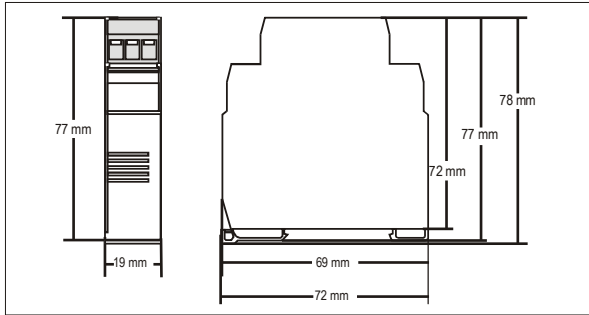

Figure 4 – ATxRail dimensions

## ELECTRICAL CONNECTIONS

### Connector specification:

- Insulating material: Polyamide, self-extinguishing to UL 94, V-0
- Connection wire cross section: 0,14 - 4.0 mm<sup>2</sup>
- Screw tightening torque: 0,8 Nm / 7.0 lb-in
- Terminal block: CuZn

### It is important to follow the recommendations below:

- Signal wires should be installed in grounded conduits and away from power or contactor wires.
- The instrument should have its own power supply wires, which should not be shared with electrical motors, coils, contactors, etc.
- Installing RC filters is strongly recommended at contactor coils or any other inductors.
- System failure should always be taken into account when designing a control panel to avoid irreversible damage to equipment or people.

Figure 5 below shows the ATxRail connections to the sensor and power supply. Terminals 1, 2 and 3 are used for sensor input. For 2-wire Pt100, terminals 2 and 3 shall be connected together.

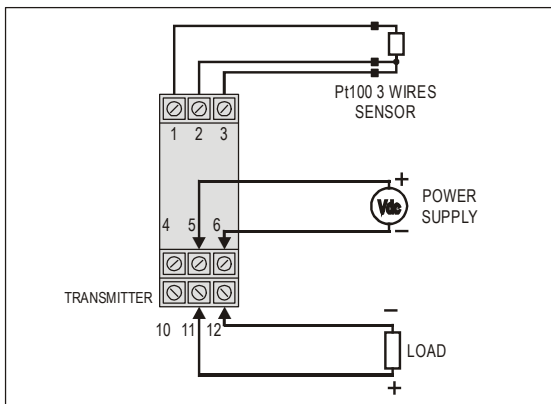

Figure 5 – ATxRail wiring (Pt100)

Figure 6 below shows the thermocouple wiring.

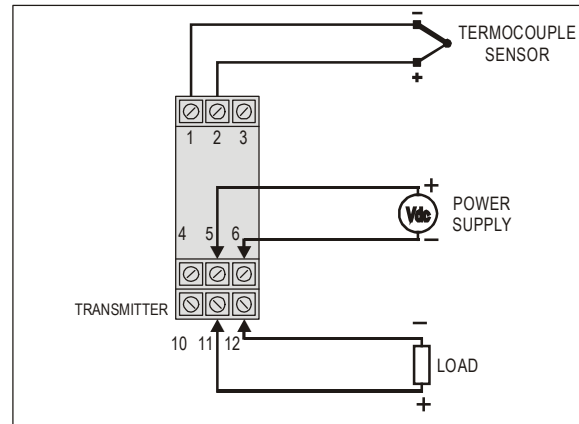

Figure 6 – ATxRail wiring (Thermocouple)

## OPERATION

All input types and the 0-10Vdc output are factory calibrated. However, a manual offset trim is implemented to provide fine adjustments to the signal in the field. This is accomplished by the front keys ZERO+ and ZERO-. Using a small tool, press and hold the desired key for at least 2 seconds to increase or decrease the output. The offset adjustment is capable of varying the output current by an amount equal to  $\pm 5\%$  relative to the original calibration..

The offset correction can also be accomplished by the ATxConfig software. See in Figure 3 the **Zero Correction** field for this purpose. The serial adaptor can be connected to the transmitter while it is operating in the process.

**Note:** when using a Pt100 simulator, make sure the ATxRail Pt100 excitation current (0.18mA) is compatible with the simulator specification.

The input types are listed in Table 1, along with the maximum and minimum ranges accepted by each one. The ATxConfig software will allow only configurations that are consistent with the data in this table.

Please note that the specified accuracy is referenced to the maximum span of each input type. For instance, for the Pt100 input, the 0.2% accuracy results in 1.7°C total accuracy  $[(650 - (-200)) \times 0.2]$ .

# MICROPROCESSOR BASED TEMPERATURE TRANSMITTER

## ATxRail 0~10VDC

### INSTALLATION AND OPERATING MANUAL



**ABUS TECHNOLOGIES INC.**

## PRESENTATION

The ATxRail is a DIN rail mount temperature transmitter. Microprocessor based, it was designed for flexibility, accepting mV, Pt100 and a variety of thermocouples as the input sensor. The ATxRail delivers a scalable linear 0-10Vdc output voltage proportional to the sensor temperature. A user-friendly configuration software is provided for parameter setup, including sensor type, temperature range, filter, etc.

## SPECIFICATIONS

**Sensor input:** User defined. The supported sensors are listed in table 01, along with their maximum ranges.

**Thermocouples:** Types J, K, R, S, T, N and E, Impedance >> 1M $\Omega$ , according to IEC 60584-1 (ITS-90).

**Pt100:** Excitation: 180 $\mu$ A, 2 or 3-wire connection (for 2-wire sensors, tie terminals 2 and 3 together).  
 $\alpha$ = 0.00385, according to IEC 60751(ITS-90).

**Voltage:** 0 a 50mVdc.  
Impedance >> 1M $\Omega$

Sensor Type	Range	Minimum measurement span
Thermocouple K	0 a 1370°C	100°C
Thermocouple J	0 a 760°C	100°C
Thermocouple R	0 a 1760°C	400°C
Thermocouple S	0 a 1760°C	400°C
Thermocouple T	0 a 400°C	100°C
Thermocouple N	0 a 1300°C	100°C
Thermocouple E	0 a 720°C	100°C
Pt100	-200 a 530°C	40°C
Voltage	0 a 50mV	5mV

Table 1 – ATxRail input sensors

**Output:** 0 to 10Vdc, linear with respect to the measured temperature.

**Total accuracy:** better than 0,25% of the maximum range for thermocouples and 0,15% for Pt100 and voltage (for voltage output above 100mV).

**resolution:** 0,025V (12 bits)

**Response Time:** < 100 ms;

**Power supply:** 18 to 30Vdc

**Maximum Current (Load):** 2mA

**Operating Temperature:** -40 to 85°C

**Humidity:** 0 a 90% RH

**Electromagnetic compatibility:** EN 50081-2, EN 50082-2

**No isolation between input, voltage output and power supply.**

**Internal protection against polarity inversion.**

**Cold junction compensation for thermocouples.**

**Housing:** ABS plastic. Dimensions: Refer to figure 4.

## CONFIGURATION

Please check the configuration parameters programmed in the ATxRail, using the **ATxConfig** software. A communication path needs to be established between the ATxRail and the serial port of a PC. The 1,5m long **ATxConfig Interface** is provided for this purpose. Connect its DB9 end to the PC COMM port and the other end to the transmitter as shown in Figure 1.

Once configured, the transmitter is ready to be installed in the process.

**Note:** The ATxConfig Interface and Software can be purchased separately from **ABUS** or one of its distributors. The latest release of this software can be downloaded from our website [www.abustek.com](http://www.abustek.com). Do not save the ATxConfig software into a file which contains accent marks. To install, run the **ATx\_setup.exe** and follow the instructions. To install the configurator, run the **ATx\_setup.exe** file.

Serial port configuration errors may occur when other devices are sharing the same port (ex.: Palm Hot Synch). Close all serial port applications prior to using the ATxConfig software.

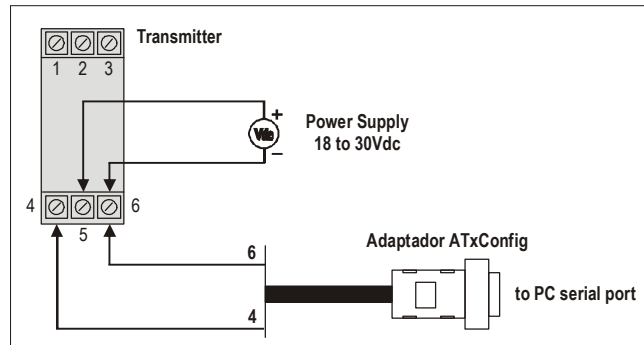

Figure 1 – Adaptor connections to the ATxRail

The transmitter requires to be powered during the configuration.

The **ATxConfig** screen is shown in Figure 3. All user parameters can be seen and/or modified by either typing a value or selecting among the available options.

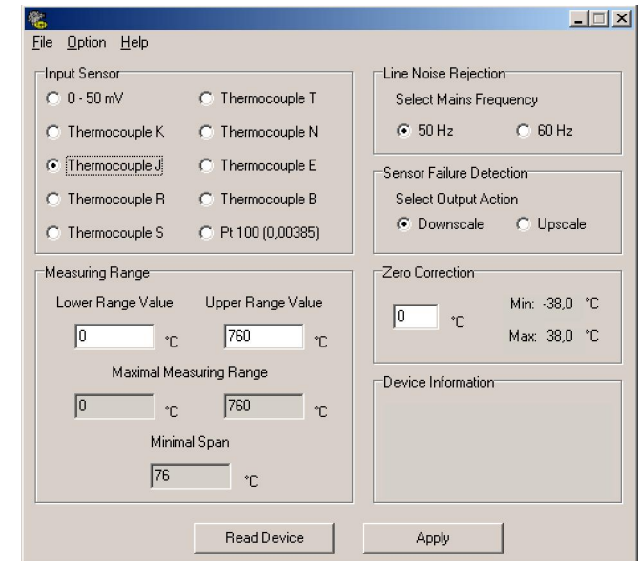

Figure 3 –ATxConfig main screen

The fields in the screen mean:

1. **Input Sensor:** Choose the desired temperature sensor among the available options.

2. **Measuring range:** Defines the beginning and the end of the range.

**Lower Range Value:** sets the value of the input signal (temperature or mV) associated to the 0V output.

**Upper Range Value:** sets the value of the input signal that will correspond to the 10V output

The values configured in these fields can not be beyond the sensor measuring range. The minimum span value has to be observed as well (see Table 1).

3. **Line Noise Rejection:** The ATxRail incorporates a digital filter to cancel the induced noise from the 50 or 60 Hz systems. For better performance, select the line frequency used in your country.

4. **Sensor Failure Detection:** establishes the transmitter output behavior (upscale or down-scale) in the presence of a sensor fail.

5. **Zero Correction:** Allows for small sensor corrections.

6. **Read Configuration:** Brings to the screen the current ATxRail parameters configuration.

7. **Apply:** Sends a new configuration to the transmitter.

8. **Device Information:**

The *Device Information* box contains relevant data concerning a particular ATxRail transmitter. Please pass along this information when contacting the technical assistance department.

**Note:**

The factory default configuration is (unless otherwise specified or ordered):

- Pt100 input, 0 to 100°C
- 60Hz filtering and upscale (10Vdc) output for sensor fail.